

Introduction

This manual is intended to provide a description of the LAN-USB CONNECT network FTP data server. The LAN-USB CONNECT is an FTP server with at least 2 GB of local memory stored on a removable SD card. Data can be accessed over a LAN network as well as directly off the SD card when the card is used with a computer. Additionally, this unit comes with a USB port, in case at any point you prefer to use a USB thumb drive instead.

Requirements

The LAN-USB CONNECT device will work with a CNC control with a standard DB25 RS-232 serial connection to the control box for the purposes of input/output of CNC data. Typically, the CNC manufacturer refers this as read and punch tape functions. Power is obtained from the CNC machine tool.

Description of Operation

The LAN-USB CONNECT acts as an FTP server for file storage that an operator can access at the control panel on a CNC. Connection to the FTP server can be done with standard software tools that are provided with most PC's. No logon is required as the LAN CONNECT FTP Server accepts anonymous logins. Special software is not required. The most popular of these are Explorer and Internet Explorer from Microsoft. Anyone on the network can drag and drop files to the CNC server where they can be transferred to machine memory or drip fed (DNC). Conversely, files residing in CNC memory can be sent to the data server where they can be accessed by anyone on the network.

File information is stored on an SD card resident on the LAN-USB CONNECT. A 2 GB SD card is provided as standard. Other sizes may be substituted. In the event of a network outage, the SD card may be removed and inserted into a PC. Files can be added or stored at the PC and replaced in the LAN-USB CONNECT.

Note: Files should follow the 8.3 format for proper operation. E.g. File name should not exceed 8 characters and the suffix should not exceed 3 characters.

Navigating the Menus

There are three buttons on the panel of the LAN-USB CONNECT device. Two square buttons bracket a round button in the center. The square round buttons are used to control the cursor in order to highlight options from a menu or file selection. The cursor is typically shown bracketing items with > and < symbols. The center button typically selects the options or files highlighted with the > and < symbols.

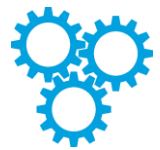

Main Menu

The following is the main menu displayed upon application of power. The outer round buttons are used to adjust the item to be selected either up or down. The center button is used to select the function that is highlighted with the > < symbols. The descriptions of each function are described later in the manual.

```
Select:>CNC to File<|
      File to CNC
      DNC
v3.92  SETUP
```

CNC to File Menu Selection

With this selection, CNC data can be sent directly to the local ftp server memory. The file name used to transmit CNC data is generated automatically*. You will need to select either [SD Dir] or [USB Dir], depending on whether you wish to save to the SD card (LAN) or USB stick. A different file name can be typed in by selecting [Type File].

```
to CNC: MOLD.TXT

View   Start  Cancel
```

Shown in the above screen display, the file name CNC16.TXT has been automatically generated by the LAN-USB CONNECT control. Press the button under the **Start** option to prepare the ftp server memory storage to receive a file from the CNC. Press the button under the Cancel option to return to the main menu without creating a file. Once the “Start” has been pressed, a file send operation (punch) from the CNC should be initiated.

**More about the Automatic File Name Selection: All files saved to the ftp server memory storage use a file name with the following structure: CNC####.TXT. The number will be the next number in the sequence of the files found on the ftp server. If the largest sequence numbered file name number found is CNC15.TXT, then the next file name created will be CNC16.TXT.*

File to CNC Menu Selection

With this menu selection, a file on the ftp server memory can be sent directly to the CNC. The first files shown on the display are files on the ftp server memory from the most recently accessed directory. First you will need to select [SD Dir] or [USB Dir] depending on whether you wish to pull the file from the SD Card



(LAN side) or the USB stick. Use the buttons on the right and the left to highlight a particular file, highlight [type file] to type in a file name, or select a new sub directory to display. Press the center button to make the selection desired.

```
[type file]
CNC16.TXT
>MOLD.TXT<
NEXTJOB<DIR>
```

Shown in this example screen above, the MOLD.TXT file is highlighted. Select the center key to prepare the file to be sent. A new screen will appear showing the file to be sent along with a Start and Cancel display. Before pressing the Start button, prepare the CNC control to receive a file. When the CNC is ready to accept a file, press the center button associated with the Start button on the screen. Press the right button to cancel this operation and return to the main menu. Use the View option to view the contents of the file selected before sending the file to the CNC.

```
to CNC: MOLD.TXT

View   Start  Cancel
```

After pressing Start, the CNC should now receive the data file selected. In the example above, file data contained in MOLD.TXT will be sent to the CNC. When the transmission is complete, the display will return to the main menu. On some machines, the operator may have to press cancel to return to the main menu after transmission of a file.

DNC* Menu Selection

With DNC selection, a file on the ftp server memory can be sent directly to the CNC while the control is in Automatic mode. This function provides a way to 'run' a program off the ftp server memory. The first files shown on the display are files on the ftp server memory from the most recently selected directory. Use the buttons on the right and the left to highlight a particular file, highlight [type file] to type in a file name, or select a new sub directory to display. Press the center button to make the selection desired.

*(DNC, Direct Numerical Control, may not be available on all CNCs. Check with the machine's User Manual to determine if this is available on the CNC control).



```
[type file]
CNC16.TXT
>MOLD.TXT<
NEXTJOB<DIR>
```

Shown in this example screen shot, the MOLD.TXT file is highlighted and selected. Press the Start button. This will prepare the LAN CONNECT for DNC or “drip feed operation”. Next, place the CNC in Automatic or DNC mode. The LAN CONNECT will begin sending the file when the CNC is put in DNC or Automatic Mode. **It is important to prepare the LAN CONNECT first when using software handshaking.**

Auto-rewind: Once a file has been sent to the control, the LAN CONNECT will “rewind” to the beginning of the program. In order to repeat the file, simply press start again to machine another part as many times as desired. Press the right button to cancel this operation and return to the main menu.

```
DNC Options Menu

Mid-      Prep-
tape     Cont.  data
```

Select Options to display the options menu as shown below in the example. The options menu allows for mid-tape starts and preparatory lines to be added to the file that has been selected.

```
Preparatory Data:
T4M6
(delete=Left/Right)
Scroll Cont.  Next
```

Use the Mid-tape start option to do a block search of the file selected for DNC. DNC will start at the block of NC code that contains the mid-tape text entered. For example, suppose the operator were to type in N1000.2. DNC will begin when a block that contains "N1000.2" is found. Note: An N word can be added to a single line of the file in order to establish a starting block number.

Use the Preparatory data option to insert text before the file that is selected for DNC. For example, the operator might want to make a tool change prior to running a file or position the Z axis. To do this, the operator would enter the appropriate NC codes to make a tool change like T4M6.



```
Preparatory Data:  
T4M6  
(delete=Left/Right)  
Scroll Cont. Next
```

"The mid-tape or preparatory text can be typed using the left and the right buttons under the display. The Scroll function is used to increment to another letter or number. Use the Next function to accept that character and move to the next character in the text. Use the Cont. function to accept this as the file name. A character can be deleted by pressing the Left and Right buttons at the same time.

Setup Menu Selection

The Setup selection allows settings to be established for the RS-232 serial communication with the CNC. Highlight the parameter option from the list. Press the center button to select the highlighted option.

```
>Baud Rate<  
Flow Control  
End Of Block  
Delay
```

Baud Rate

Set the Baud Rate to communicate to the CNC. The baud rate is the number of bits per second the RS-232 serial port will communicate. The available choices are:

- 1200
- 2400
- 4800
- 9600
- 19,200
- 38,400
- 57,600
- 115,200



Data/Parity/Stop

Set the number of Data, Parity and Stop bits used for serial communication. This setting is typically fixed on a CNC. Refer the CNC’s manual for the proper combination. The following choices are available:

- 7 data, Even parity and 1 stop bit
- 7 data, Even parity and 2 stop bit
- 8 data, no parity and 1 stop bit
- 8 data, no parity and 2 stop bit

Flow Control

Flow control sets the streaming method of data to and from the CNC. This is typically a fixed method. Refer to the CNC manual to determine which type is used by the CNC. Hardware flow control uses two RS-232 signals (CTS and RTS) to start and stop data transmission. Software flow control uses XON/XOFF characters to start and stop data transmission. Software flow control is the preferred and easiest method to implement. This method is recommended.

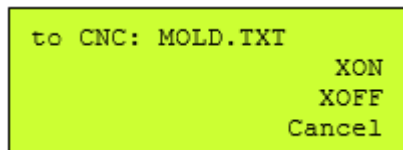

When the Software flow control method is used, the current XON or XOFF that has been received during transmission will be displayed on the right of the display. Use this feedback to determine if the LAN CONNECT unit is receiving XON or XOFF characters.

End of Block Char

End of block sets the format for end of block characters. The most common end of block is the carriage return/ line feed used by most PC computers. The next most common is the Teletype end of block, which is line feed/carriage return. This parameter value will be the end of block that is used when sending data to the CNC. When data is received from a CNC, a carriage return/line feed end of block is always used so the file can be viewed when view the file using a computer.



The following choices are available:

CR LF LF CR
LF CR CR LF
CR None/binary

Use the 'None/binary' for controls that do not use text files or a file that does not contain control characters. For example, Mazak has an optional non-G code file system that will not work in text mode. The LAN CONNECT will transfer those files when the binary option is selected.

End of Block Delay

Delay set a pause at the end of a block of data. Typically, this is set to 'no delay' to ensure the fastest data communication at the selected baud rate. Choose a delay if the CNC manufacturer requests a delay at the end of a block or if the CNC is losing blocks of data in the program. This feature is typically used for older CNC's with low communication and baud rate capability.

Start of Tx

This sets the character that will be sent prior to sending data in the selected file. The most common character used is the percent, %. Choose a setting as specified in the CNC manual. If your file already contains a % at the beginning, set to none so duplicate % signs are not sent.

The following choices are available:

%
null char
none

Use the null character for controls the need an ASCII char 0 to be used as the start character.

End of Tx

This function sets the character that will be sent after sending data in the selected file. The most common character used is the percent, %. Choose the setting as specified by the CNC manual.

The following choices are available:

Shop Floor Automations, Inc.
5360 Jackson Drive, Suite 202
La Mesa, CA 91942-6003

Phone: (619) 461-4000
Toll Free: (877) 611-5825
Fax: (619) 461-5918

Web: www.shopfloorautomations.com
Email: support@shopfloorautomations.com

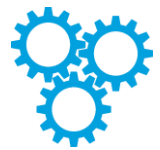

%
null char
none

Use the null character for controls the need an ASCII char 0 to be used as the end character.

Probe RS-232

This function shows the current RS-232 levels present. This can be used to help diagnosis serial issues.

Start Rx

This sets how the LAN CONNECT will initiate receiving a file. Some machines require an initial XON to begin the transmission. Most machines do not, so the 'automatic' setting will work for most machines.

Notes:

The LAN CONNECT does not support long Windows type file names. Use a DOS type 8.3 file format with the LAN CONNECT. 8.3 filenames have at most eight characters, optionally followed by a "." and a filename extension of at most three characters.

Deciding on a network configuration

There are several ways to design a network. Some knowledge and experience with setting up networks is highly suggested. The simplest example shown below is of a peer- to-peer network where there are only two devices connected. The other examples shown below expand the number of computers and LAN CONNECT possible on the network.

Using the simple peer-to-peer network is a good starting point when setting up a new network or before integrating the LAN CONNECT and CNC into a larger company network.

The following are the suggested manufacturers of routers and access points:

Belkin 4-Port Cable/DSL Gateway Router F5D5231-4

Belkin Wireless G Router F5D7230-4 (this can be configured as an access point) Belkin Wireless G Router P57612-G (this can be configured as an access point)

Shop Floor Automations, Inc.
5360 Jackson Drive, Suite 202
La Mesa, CA 91942-6003

Phone: (619) 461-4000
Toll Free: (877) 611-5825
Fax: (619) 461-5918

Web: www.shopfloorautomations.com
Email: support@shopfloorautomations.com

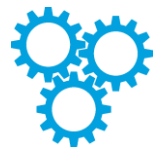

Example 1, Simple Peer-to-peer Network connection to the LAN CONNECT

The diagram below shows a simple peer-to-peer configuration of integrating a computer (i.e. desktop or laptop computer running Windows, MAC or Linux OS), the LAN CONNECT controller and a CNC. This simple setup is good starting point when setting up a new network or before integrating it into a larger company network.

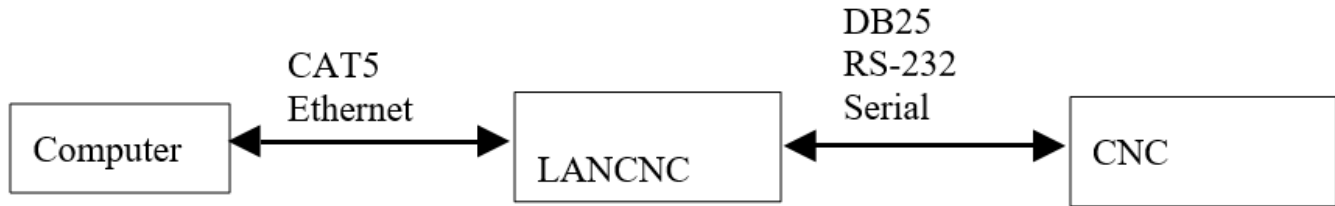

The LAN CONNECT has a factory default ftp server address of 192.168.2.111. Direct connection to a Windows PC out of the box with an Ethernet cable can be achieved by following the subsequent procedures:

1. Open the Control Panel from the Windows Start button. The screen should look like Figure 1.

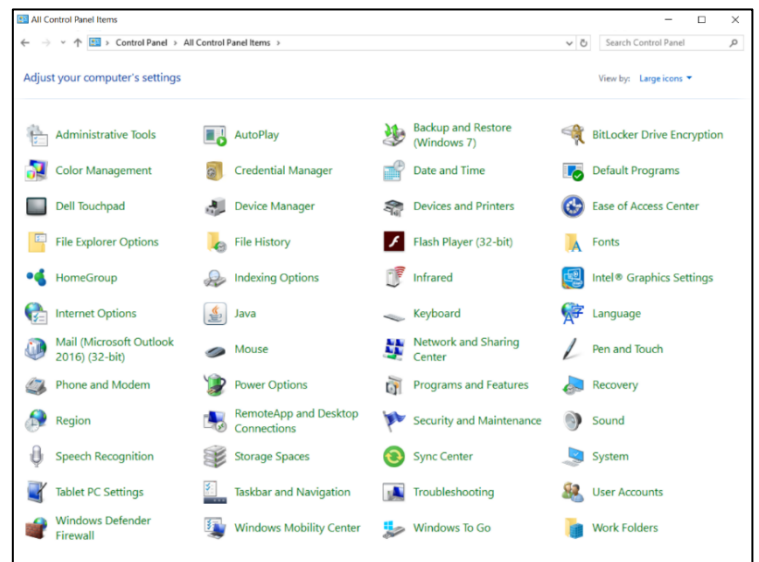

Figure 1

2. Select “Network and Internet” or “Network and Sharing Center,” then select “Network Connections” and the screen should look like Figure 2.

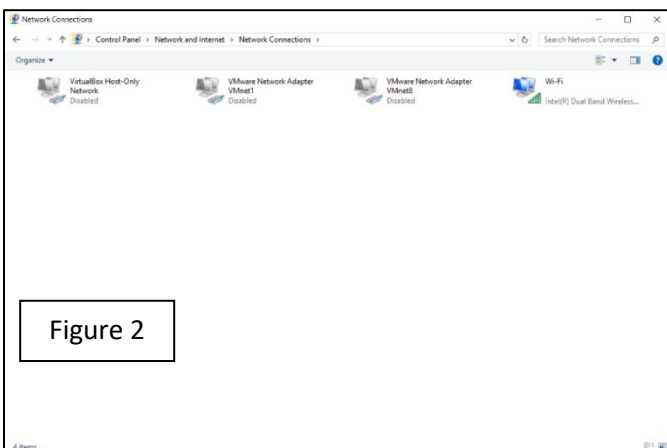
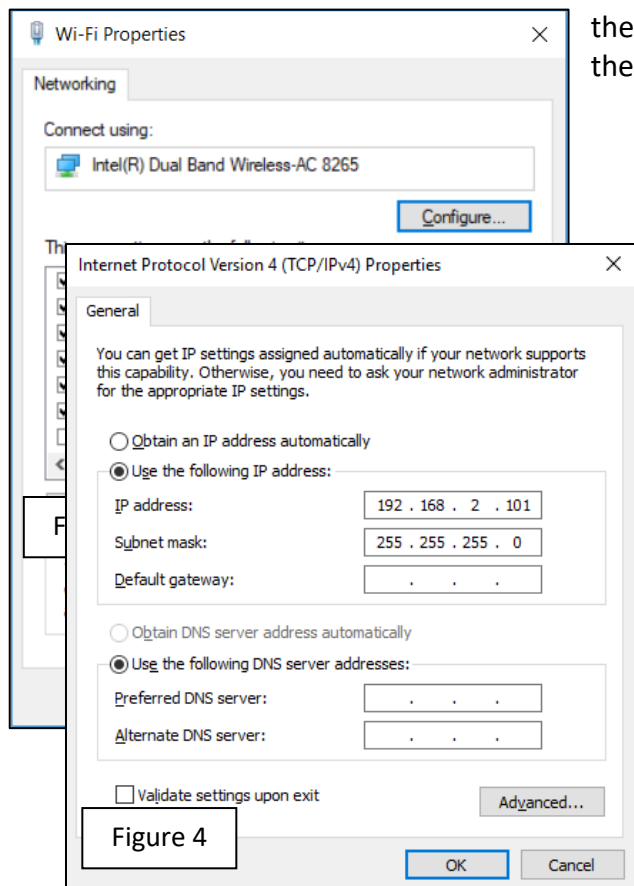

Figure 2



3. Highlight the “Local Area Connection” and right click mouse. A box should appear. Select “Properties” and screen should look like Figure 3.
4. Select “Internet Protocol Version 4 (TCP/IPv4)” so that it is highlighted and click the “Properties” button.
5. A new screen will pop up (Figure 4). Select the button “Use the following IP address:” and type in an address of 192.168.2.101. The sub-net mask should be 255.255.255.0. Click “OK”. The “Local Area Connection Properties” menu will be displayed. Click “Close”. There will be a slight delay while your PC applies these new settings.
6. You may exit from the Control Panel. Start Internet Explorer and type ftp://192.168.2.111 in the address bar. A screen similar to the one shown in Figure 8 should appear. A number of files are loaded on the SD card when shipped for testing purposes. A message will appear “To view this FTP site in Windows Explorer, click Page, and then click Open FTP Site in Windows Explorer.”



the
the

Figure 4

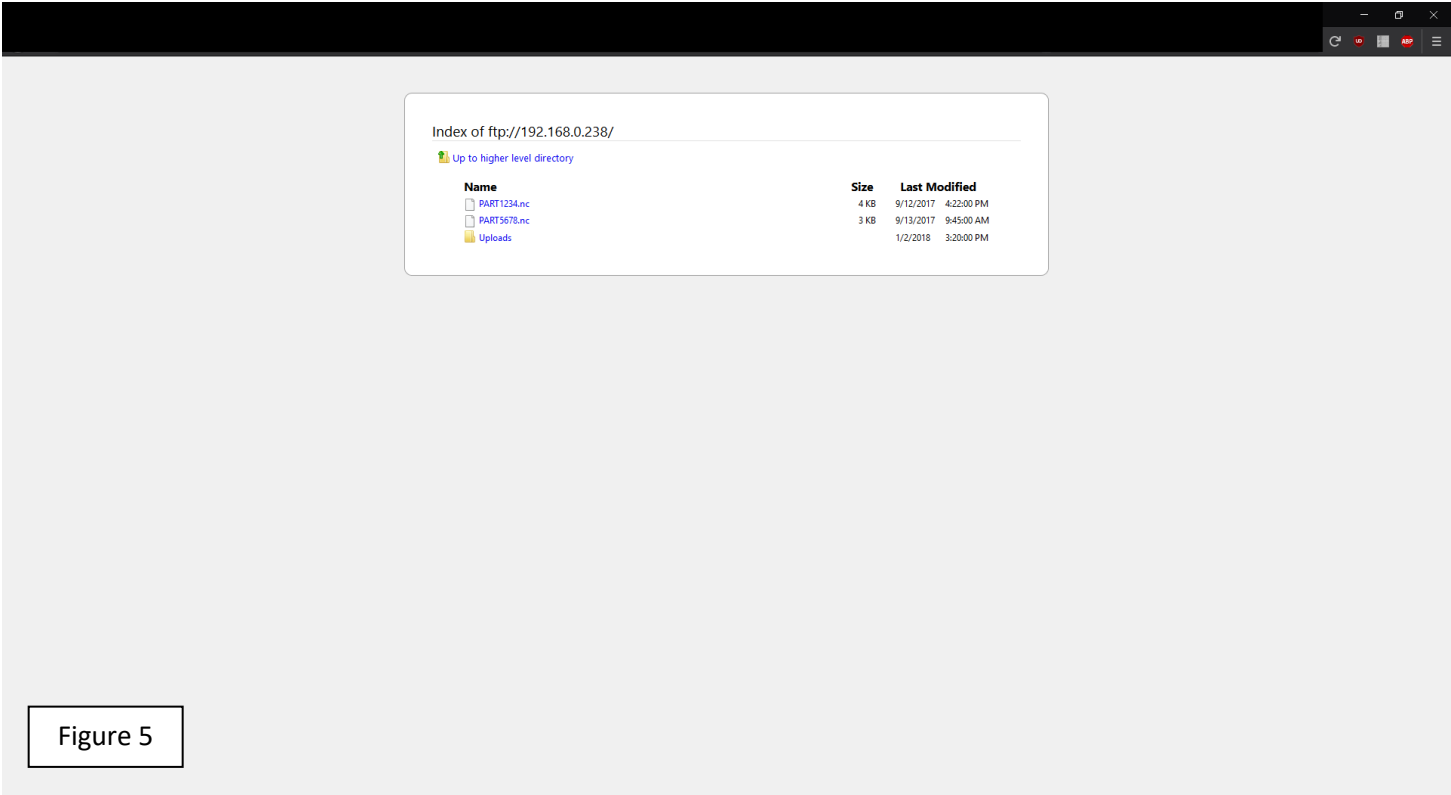

Figure 5

Follow the instructions that come up in Internet Explorer to view the files in an FTP viewer window. (Click “Page”, and then click “Open FTP Site in Windows Explorer” in the drop-down box.)

The figure below shows the display on a PC when the ftp site has been opened from the previous step. At this screen, files can be transferred from any file folder on your PC and the FTP site. If you wish to create a new directory on the FTP site, create a file folder somewhere on your PC such as “My Documents”. Select the folder and drag and drop with your mouse to the ftp window shown above. The file directory as well as any files inside the directory will be copied to the LAN-USB CONNECT ftp site.



As an alternate, there are a number of ftp software programs that are available that offer additional ftp options for managing your files. Additional features offered are logging file transfer activity, data rate transfer, and comparisons of directory data.

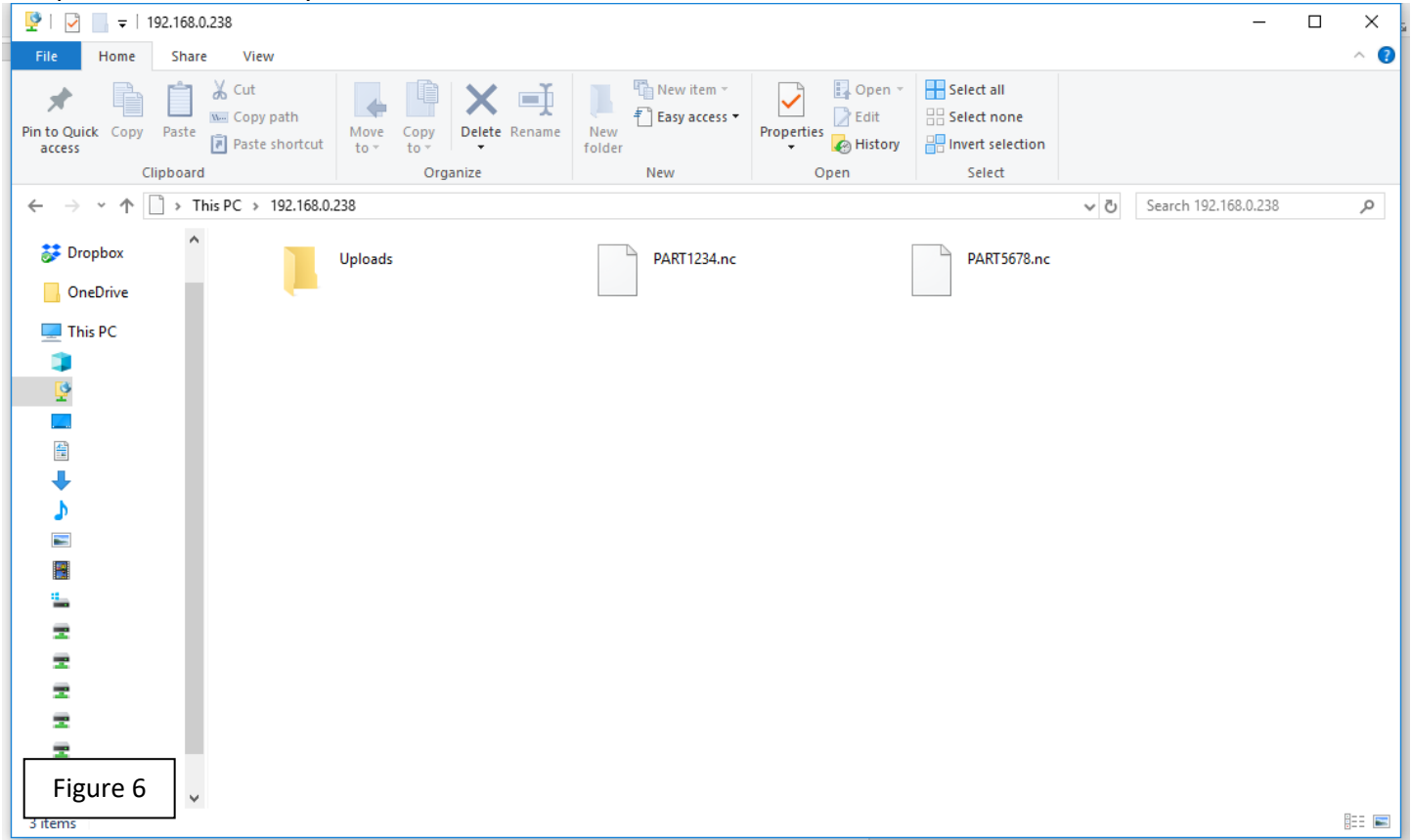

The figure above shows the display on a PC when the ftp site has been opened from the previous step. At this screen, files can be transferred from any file folder on your PC and the FTP site. If you wish to create a new directory on the FTP site, create a file folder somewhere on your PC such as “My Documents”. Select the folder and drag and drop with your mouse to the ftp window shown above. The file directory as well as any files inside the directory will be copied to the LAN-USB CONNECT ftp site.

As an alternate, there are a number of ftp software programs that are available that offer additional ftp options for managing your files. Additional features offered are logging file transfer activity, data rate transfer, and comparisons of directory data.

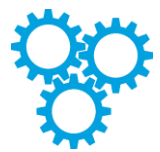

Example 2, Wired Network connection to the LAN-USB CONNECT using a router

The diagram below shows a wired network configuration using a network router. The router connects multiple networking devices together.

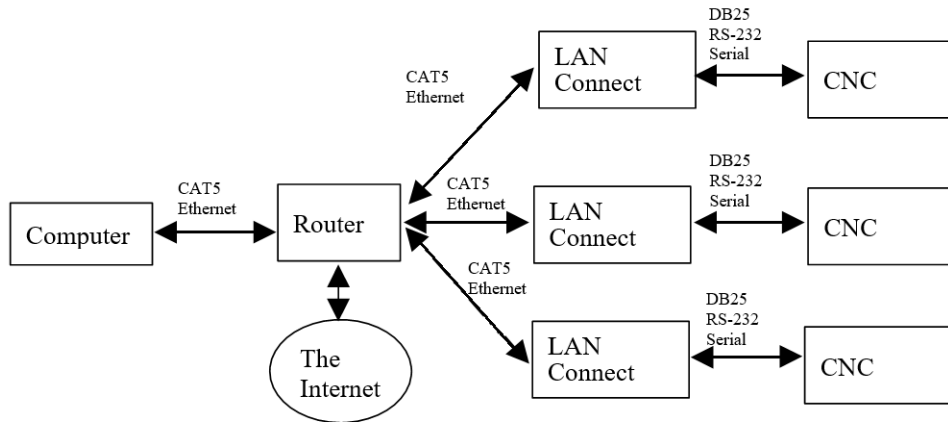

The IP address of the router is required to setup the LAN-USB Connect. There may be some changes on the router also. The following are the suggested settings on the router:

DHCP enabled (On)

IP Address: 192.168.2.1

Subnet Mask 255.255.255.0

IP Pool Starting Address 192.168.2.2

IP Pool Ending Address 192.168.2.100

Using these settings on the router will allow computers on the network to automatically get their own IP addresses in the range of 192.168.2.2 to 192.168.2.100. And it leaves 192.168.2.101 and above to be available to static IP address like the LAN-USB CONNECT devices. It is important to note that only one device can use an IP address at a time. The router, computers, printers, and LAN-USB CONNECT devices need to have their own number in the network range provided by the IP address and Subnet Mask. In the suggested settings above the only address available to the network devices is between 192.168.2.1 and 192.168.2.254. The following is an example of IP addresses that could exist:

- 192.168.2.1 is the Belkin Routers IP address (fixed in the router settings)
- 192.168.2.2 is a desktop computer IP address (automatically provided by the DHCP)
- 192.168.2.3 is a laptop computer IP address (automatically provided by the DHCP)
- 192.168.2.4 is a printer IP address (automatically provided by the DHCP)



- 192.168.2.101 is a LAN-USB CONNECT IP address (set in LANCN.C.INI on the SD card)
- 192.168.2.102 is a LAN-USB CONNECT IP address (set in LANCN.C.INI on the SD card)
- 192.168.2.103 is a LAN-USB CONNECT IP address (set in LANCN.C.INI on the SD card)

The following (Figure 7) is an example of what a network router LAN configuration page should look like. You typically access the LAN settings via a web browser and type in the routers IP address, in this example it is 192.168.2.1. This is a typical IP address of routers.

- This is the IP address of the router. If you type 192.168.2.1 into a web browser it will access the displayed router settings pages shown. The first three numbers will need to be the same on the connected LAN CONNECT devices. The last number is essentially the device number. The router is 1, the computers will be provided a number from 2 to 100, and the LAN CONNECT will need to have a number from 101 to 254.
- This is the subnet mask. This should never be changed.
- Basically, these settings will provide 99 IP addresses to the DHCP, so that 99 computers can automatically get an IP address from the router’s DHCP. It also frees up IP addresses from 101 to 254 to static IP address devices, i.e. LAN-USB CONNECT.

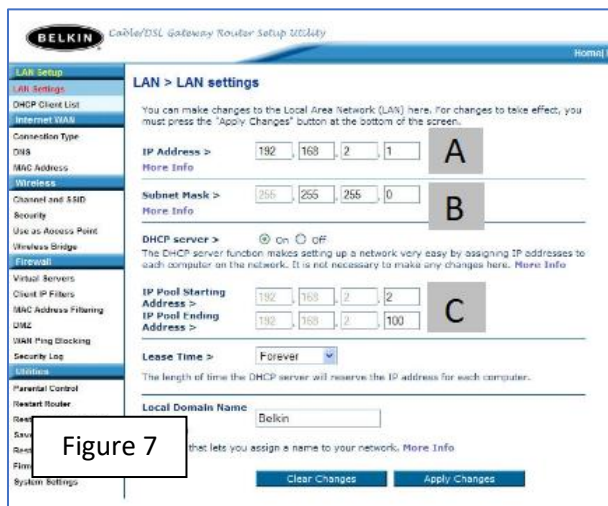



Example 3, Wireless Network connection to the LAN CONNECT using a router and a Wireless Bridge

The diagram to the right shows a Wireless Network connection to the LAN CONNECT using a router and a Wireless Bridge. It is suggested to use the router settings shown in the previous section. This configuration will use the wireless router with wireless bridging turned on to connect to another wireless router set up as an access point.

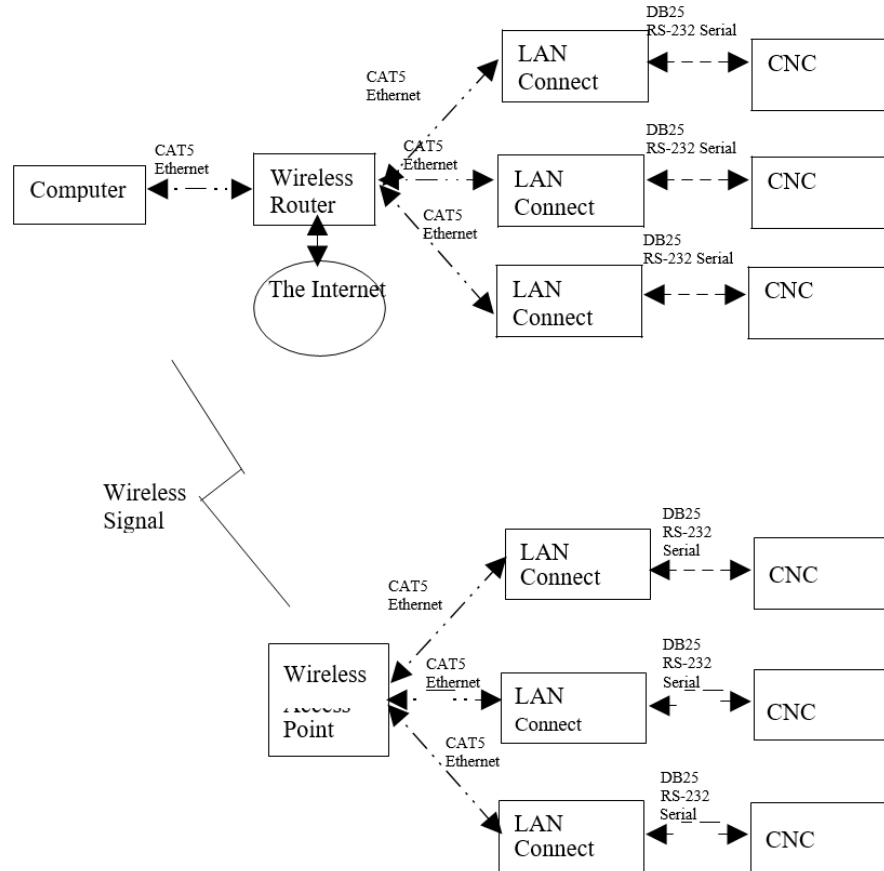

Use the following step-by-step procedure to setup the router and then the access point. These settings are based on using a Belkin Wireless G router and access point:

Router Configuration:

1. Open a Web Browser
2. In the address bar type <http://192.168.2.1>
3. Click on Wireless Bridge in the left-hand column under Wireless
4. Enter your password if any and click Submit
5. Check the box that says Enable Wireless Bridging, click Apply Changes.
6. Click Home, note the WLAN MAC address under LAN settings

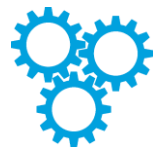

Access Point Configuration:

1. Open a Web Browser
2. In the address bar type `http://192.168.2.254`
3. Click on Wireless Bridge in the left-hand column under Wireless
4. Enter your password if any and click Submit
5. Check the box that says, Enable Wireless Bridging
6. Check the box that says, Enable ONLY specific Access Points to connect and enter the WLAN MAC address from the router, click Apply Changes.

Note: The channel must be identical on both the router and the access point.

It is important that the router and access point use the same Channel, SSID, and security settings. The access point will become another device on the routers network. When both devices are using the same wireless communication parameters, they will be able to communicate with each other.

Changing the IP address on the LAN CONNECT device

The LAN CONNECT defaults to IP address 192.168.2.111. If a different IP address is desired, use a PC to create a text file on SD card with the file name LANCONC.INI in the root directory. *This file must be text only and have carriage returns at end of each line.*

To change the IP address of the LAN CONNECT to 101, the contents of the LANCONC.INI file should look like this:

```
IP address=192.168.2.101
IP mask=255.255.255.0
IP gateway=0.0.0.0
IP DNS=0.0.0.0
```

Remember the last number on the IP address will be that CNC's "number." To access the files on that CNC's LAN CONNECT file server, type in "`ftp://192.168.2.101`" in a web browser to view the directory contents stored on the machines 2GB SD card.